

Measurement guide: Front without slope

Step 1 – External dimensions:

Measure the width and height of your front from edge to edge on the inside/rear side of the front and enter the measurements (mm) in the corresponding boxes.

Required tools:

Tape measure, pen, and the printed measurement guide.

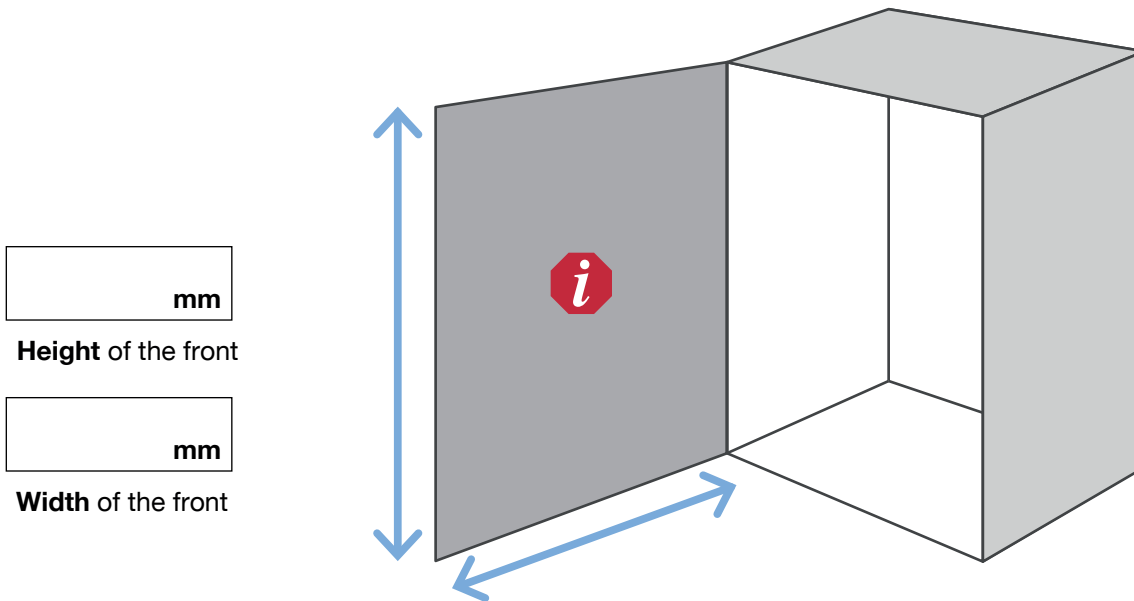

Step 2 – Hinge holes (optional):

The distances of the hinge holes are always measured from the bottom edge of your front to the center of the hinge hole. Typically, a front has 2 hinge holes. Some large fronts may have 3 to 5 holes.



Tip: Mark the center of the hinge/cup hole in advance with a pencil. You can later remove this mark with a soft eraser. If measuring in the installed position is too difficult, disassemble your front and place it, for example, on a table.

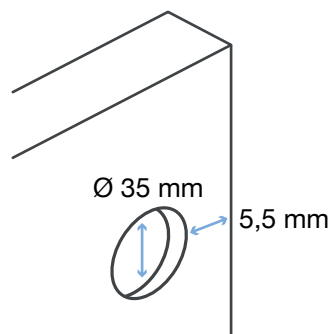
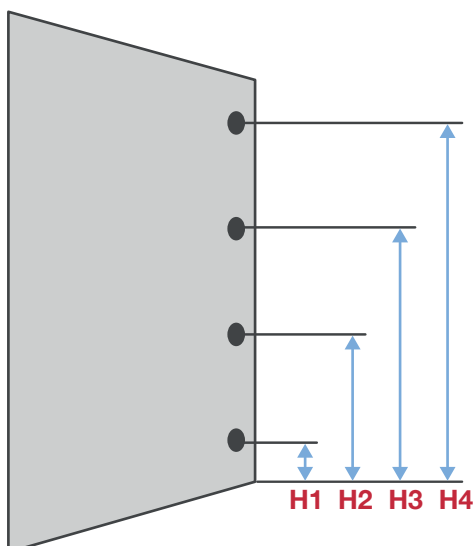

The hinge holes are set back by 5.5 mm as standard and have a diameter of 35 mm. If you want different measurements for the hinge hole, you can specify them in the configurator.

- H1** = Bottom edge of the door to the center of the hinge hole
- H2** = Bottom edge of the door to the center of the hinge hole
- H3** = Bottom edge of the door to the center of the hinge hole
- H4** = Bottom edge of the door to the center of the hinge hole

If you want holes, next measure how many millimeters your existing front overlaps the edges of your cabinet.

left _____ mm

right _____ mm

top _____ mm

bottom _____ mm

On which side is the stop of your door?

left

right

Step 3 – Handle positioning (optional):

Where would you like to position your handle?

left

right

top

bottom

You can specify the exact handle position in millimeters in the configurator.

How should the handle be aligned?

vertical

horizontal

If you already have a handle that you want to mount on your new front, please let us know the distances between the handle screws (in mm). These are always measured from the center of one screw hole to the center of the other screw hole.

Handle screw distances: _____ mm

Step 4 – Configuration:

After measuring, you can quickly and easily enter the data into the configurator at www.Furnfab.com/en/renovating-fronts.

Need help?

If you have any questions, our team is happy to assist you!

You can easily and quickly reach us via email, through our website, or by phone:

Email: service@furnfab.com

Contact form: www.furnfab.com/en/contact

Phone: +44 (0) 131 608 34 77

